



BGK *Electric Infrared
Curing Solutions*



**AUTOMOTIVE
PAINT
REPAIR PROCESS
EQUIPMENT,
SERVICE AND
DESIGN**

Your Single Source For Proprietary & Proven Electric Infrared Products And Paint Line Solutions

BGK AutoCure™



3000



5000



6000



8000

The BGK **AUTOCURE™** line of Infrared heaters provide users with a wide range of solutions to fit their production needs.

The BGK 3000, 5000, 6000 & 8000 models – available in a variety of heater head sizes – feature infrared control technology and provides easy maneuverability and accuracy for curing spot repairs.

electric linear actuator the operator uses for flexible heater positioning prior to the drying process.

The BGK Model 6000 overhead heater is specifically designed for overhead XY gantry mounting, each unit includes an

AutoCure heaters meet or exceed all standards for wiring, testing and construction and are the industry leaders when it comes to critical curing performance and reliability.

AutoCure™ 3000
Portable Heater

AutoCure™ 5000
Portable Heater

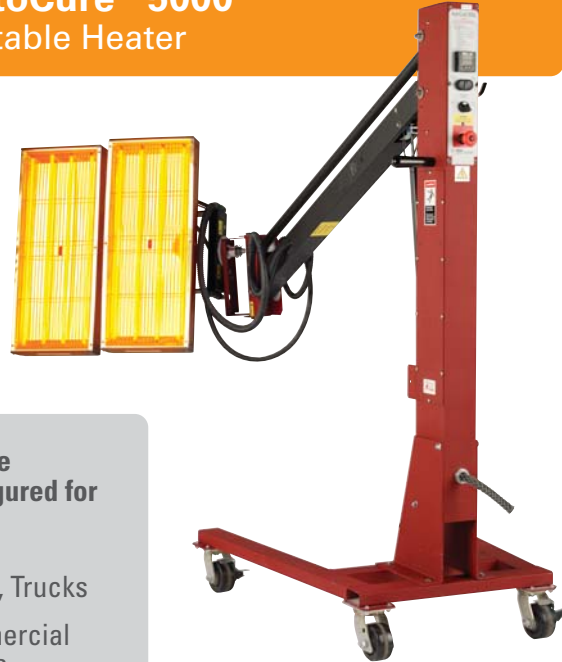
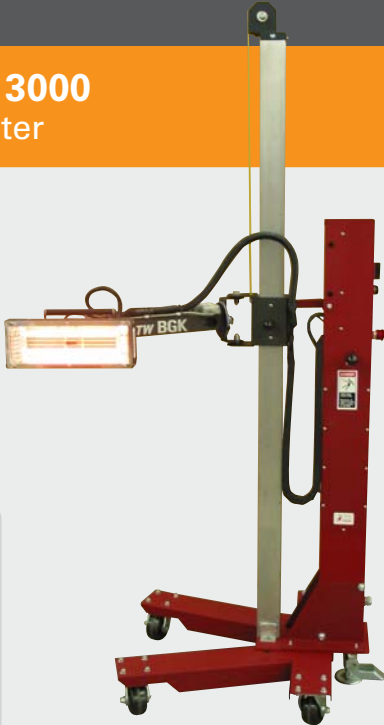

Can be configured for

- Cars
- SUV's, Trucks
- Commercial Trucks

Can be configured for

- Cars
- SUV's, Trucks
- Commercial Trucks

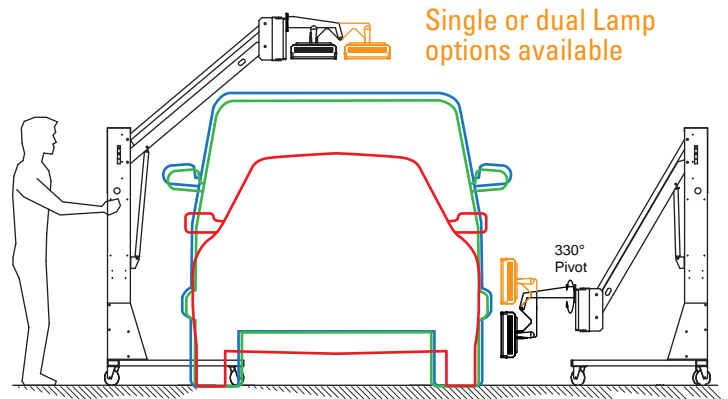
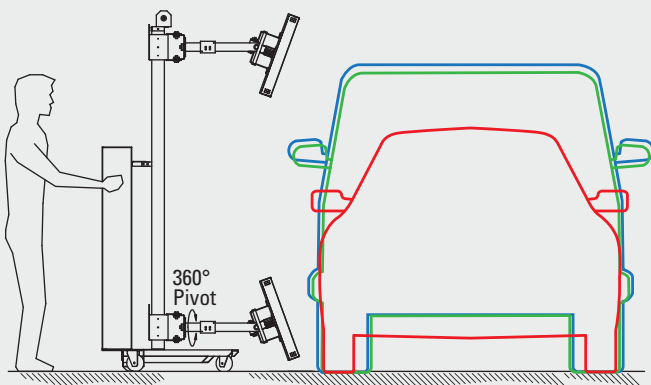

INFRARED EMITTERS

BGK Infrared Emitters incorporate unique shortwave T3 emitters exclusively manufactured for BGK equipment. Providing the most efficient heat transfer – direct and penetrating – BGK T3 emitters maximize your process and productivity.

Halogen gas filled clear quartz tubes include tantalum discs, tungsten

filaments, stainless steel leads and durable ceramic end seals, BGK Emitters provide direct, reflected and convective energy spanning all wavelengths. Rated with 5,000 hour lamp life, proprietary BGK systems routinely experience lamp life of 10,000 hours or more delivering great value.

- Accurate surface temperature control to $\pm 5^{\circ}\text{F}$
- Automatic control
- Laser Spot Sensor – Position Temperature Indicator
- Power assisted raise and lower
- Cycle-time-remaining display
- Automatic timed shut-off
- Heater head remains in place without locking handles
- Single or dual temperature setpoint capability
- Adjustable time temperature heat cycles
- Heating range to 400°F (204°C)
- Locking mechanism to maintain arm position
- Adjustable controlled ramp rates to setpoint

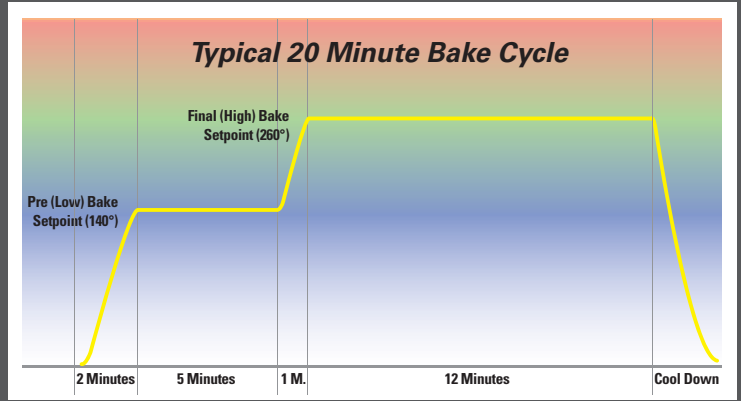

AutoCure™ 6000
Overhead Gantry Mounted Heater



Can be configured for

- Cars
- SUV's, Trucks
- Commercial Trucks

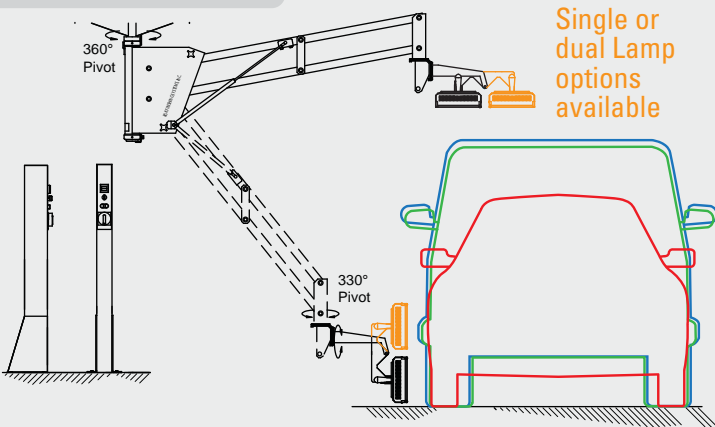

AutoCure™ 8000
Portable Panel Heater



Can be configured for

- Cars
- SUV's, Trucks
- Commercial Trucks

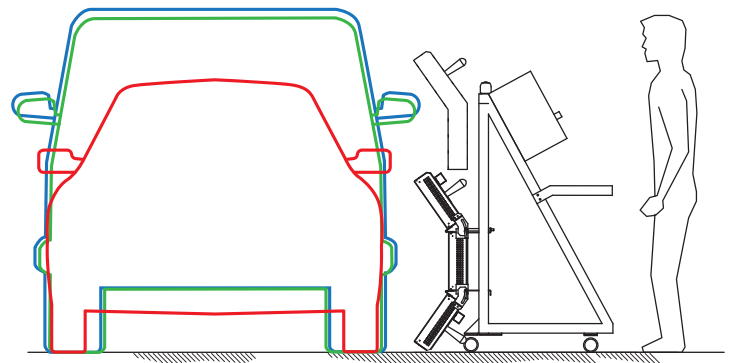

BGK Systems Routinely Experience Lamp Life Of 10,000 Hours And More!

BGK. Committed To The Worlds Highest Manufacturing Standards!





Technological Innovation Drives World-Wide Leadership

BGK is the world-wide leader in designing, fabricating and installing electric infrared curing systems for a full range of coatings operations. Whether coating with liquid, powder, PTFE, wax, UV or adhesives, BGK provides curing systems for superior quality finishes.

BGK Infrared advantages include reduced energy consumption, efficient use of floor space and increased productivity. BGK customers receive turnkey system capabilities including process verification, and after the sale service, installation, start-up and training.

BGK Offers:

- Chain-On-Edge Conveyor Systems
- Infrared Booster Ovens
- Flatline Conveyor Systems
- Overhead Conveyor Systems
- Infrared Heater Modules
- Coil Coating Systems
- IR Smart Lab Ovens
- Automotive Repair Ovens
- Automotive Portable Infrared Repair Arms
- Comprehensive Testing



Curing Paint...It's What We Do.

Matriz

Avenida Central 737
Col. Chapultepec
San Nicolas de los Garza
Nuevo Leon, México
Tel. 83-76-0690

Sucursal Saltillo

Bvd. Isidro López Zertuche No.
2616
Col. Los Maestros
Saltillo,
Coahuila, México
Tel. (01) 844-416-3096

Sucursal Mérida

Calle 5 b diagonal No. 180
entre calle 20 y 7 diagonal
Col. Juan B. Sosa
Mérida,
Yucatán México
Tel . (01) 999-981-1476 (01)
800-002- AIRE (2473)

Laboratorio de Pruebas Y Centro de Servicio

Guerrero 422
Col. Centro
San Nicolas de los Garza,
Nuevo Leon, Mexico
Tel. 83834098

